

On the Green - Green Reading

Monday, July 4th - Sunday, July 10th



GAMEON

GOLF DEVELOPMENT

Contents

- 3** Class Timetable
- 5** Class Objectives
- 9** Class Layout and Setup
- 11** Practice Stations and Game Cards
- 17** Secondary Skill
- 18** Skills Challenges



Class Timetable

Class Timetable

Session Length: 60mins

Mastering the Game Focus:
Swing
Introduction to Swing

Online Whole Golfer Resource:
Fit for Golf

Learning the Game Focus:
Aim of the Game
Equipment Requirements

Time	Activity	Class Content	Games / Drills / Resources
15 Mins Prior	Setup and Welcome	<ul style="list-style-type: none"> Set up the games and practice stations Be ready to welcome participants 5 minutes before the session starts 	
5 mins	Introduction	<ul style="list-style-type: none"> Outline the objective of the class Get the group together to introduce the Learning the Game and Whole Golfer focus Introduce the Technical Guidance for the class Explain how to play the games Explain how to attempt the practice station activities 	<ul style="list-style-type: none"> The aim of the game Overview of equipment
40 Mins	Mastering the Game	<ul style="list-style-type: none"> Learners break out to play the games individually, in pairs or groups A chance to build relationships amongst the group and between the coach/students Opportunity for private coaching Opportunity for social interaction amongst the group 	<ul style="list-style-type: none"> Practice stations Game cards Secondary skill
10 mins	Challenges and Recap	<ul style="list-style-type: none"> Outline the relevant challenges students need to complete for this skill Recap Mastering the Game and Learning the Game Focus from the session 	<ul style="list-style-type: none"> Iron play challenge
5 Mins	myGame Tracking	<ul style="list-style-type: none"> Add any lesson notes to the learner's Student Connect on GLF.Locker Learners should mark their attendance at the Themed Class in the myJourney section of the myGame area. Direct the learners to the online resources for the Whole Golfer, Learning the Game and Mastering the Game focus in the myGame area of GLF.Locker 	<ul style="list-style-type: none"> GLF.Locker / myGame App
15 Mins Post	Relationship Building	<ul style="list-style-type: none"> Take time after the class has finished to actively connect new learners Ensure everyone has their next playing or practice session booked, and take the opportunity to upsell private lessons to those that require additional help 	

© 2021 Powered by Orbis Golf

GAMEON
GOLF DEVELOPMENT

Class Timetable

Session Length:
60mins

Group Size:
1:8

Mastering the Game Focus:
On the Green
Green Reading

Online Whole Golfer Resource
Positive self-talk

Learning the Game:
Severity of slopes

Time	Focus	Class Content	Games / Drills / Resource
15 Mins Prior	Setup and Welcome	<ul style="list-style-type: none"> Set up the games and practice stations Be ready to welcome participants 5 minutes before the session starts 	
5 mins	Introduction	<ul style="list-style-type: none"> Objectives - Introduce the concept of green reading Get the group together to introduce the Learning the Game and Whole Golfer focus Introduce the Technical Guidance for the class Explain how to play the games and attempt the practice station activities 	<ul style="list-style-type: none"> Severity of slopes
40 Mins	Mastering the Game	<ul style="list-style-type: none"> Learners break out to play the games individually, in pairs or groups Opportunity for private coaching 	<ul style="list-style-type: none"> Practice stations Game cards Secondary skill station
10 mins	Challenges and Recap	<ul style="list-style-type: none"> Outline the relevant challenges students need to complete for this skill Recap Mastering the Game and Learning the Game Focus from the session 	<ul style="list-style-type: none"> Scoring challenge
5 Mins	myGame Tracking	<ul style="list-style-type: none"> Add any lesson notes to the learner's Student Connect on GLF. Locker Learners should mark their attendance at the Themed Class in the myJourney section of the myGame area. Direct the learners to the online resources for the Whole Golfer, Learning the Game and Mastering the Game focus in the myGame area of GLF.Locker 	<ul style="list-style-type: none"> GLF. Locker myGame App
15 Mins Post	Relationship Building	<ul style="list-style-type: none"> Take time after the class has finished to actively connect new learners Ensure everyone has their next playing or practice session booked, and take the opportunity to upsell private lessons to those that require additional help 	

Class Objectives



Technical Guidance

Reading Greens

The technical guidance we are prescribing is to be delivered as you see fit, use your experience and be sure to link your technical advice to how this will help learners to improve the key skills of:

Learning the effect of slope over different distances

- Where to aim if the putt is 10 feet, 20 feet or 30 feet

How to read a green that has multiple slopes

- Splitting the putt into sections and reading each section independently



Keep your technical instruction to less than 5 minutes, in order to allow maximum time for play and practice and for you to reinforce the key skills with individual tuition.

Learning the Game

Severity of Slope

Introduce the concept of learning the severity of the slope.

Using a process like Aimpoint can help to quantify the slope with a rating, e.g. a 1% slope, 5% slope, etc. When introducing this concept choose slopes that are quite extreme so that it is easier for Learners to see and feel the difference between different slopes.



The Whole Golfer

Positive Self Talk

Encourage participants to practice positive self talk is going to help them as they navigate their way through the ups and downs of learning the game of golf.

Practicing and getting into the habit of giving positive reinforcement will help to encourage learners to stick with the process of learning the game even when it becomes very difficult for them with a particular skill. A great tip is to ask them how they would respond to a child that had hit a particularly poor shot, or had a negative reaction to their practice/play, and to mirror that in the way learners speak to themselves.



Class Layout and Setup

Station 1:
Practice Station
Understanding Slopes

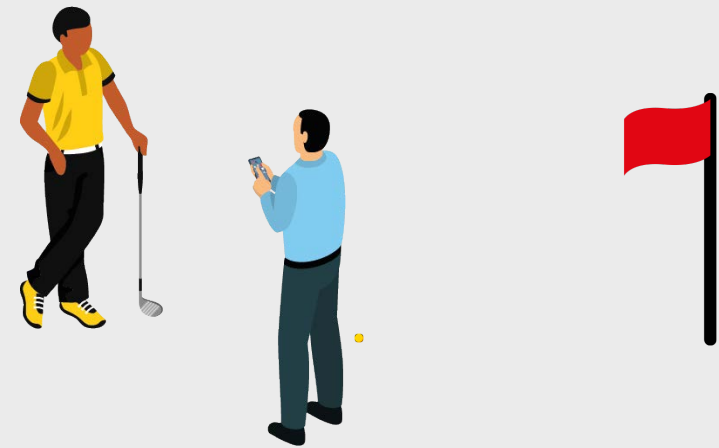

Station 2:
Practice Station
Pick a Point

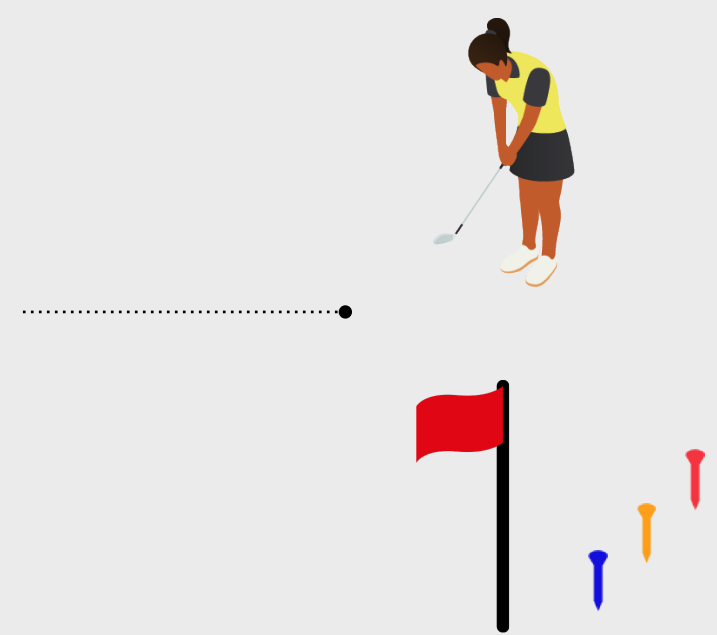

Station 3:
Practice Station
Gate Challenge

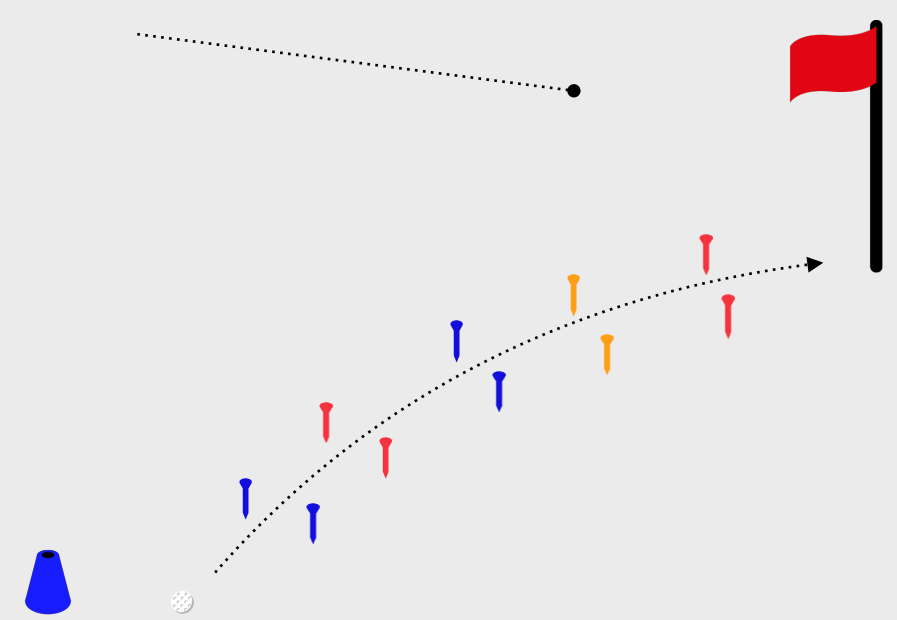

Station 4:
Game Station
Guess the Break



Station 6:
Secondary Skill
Pitching



Station 5:
Challenge Station
Scoring

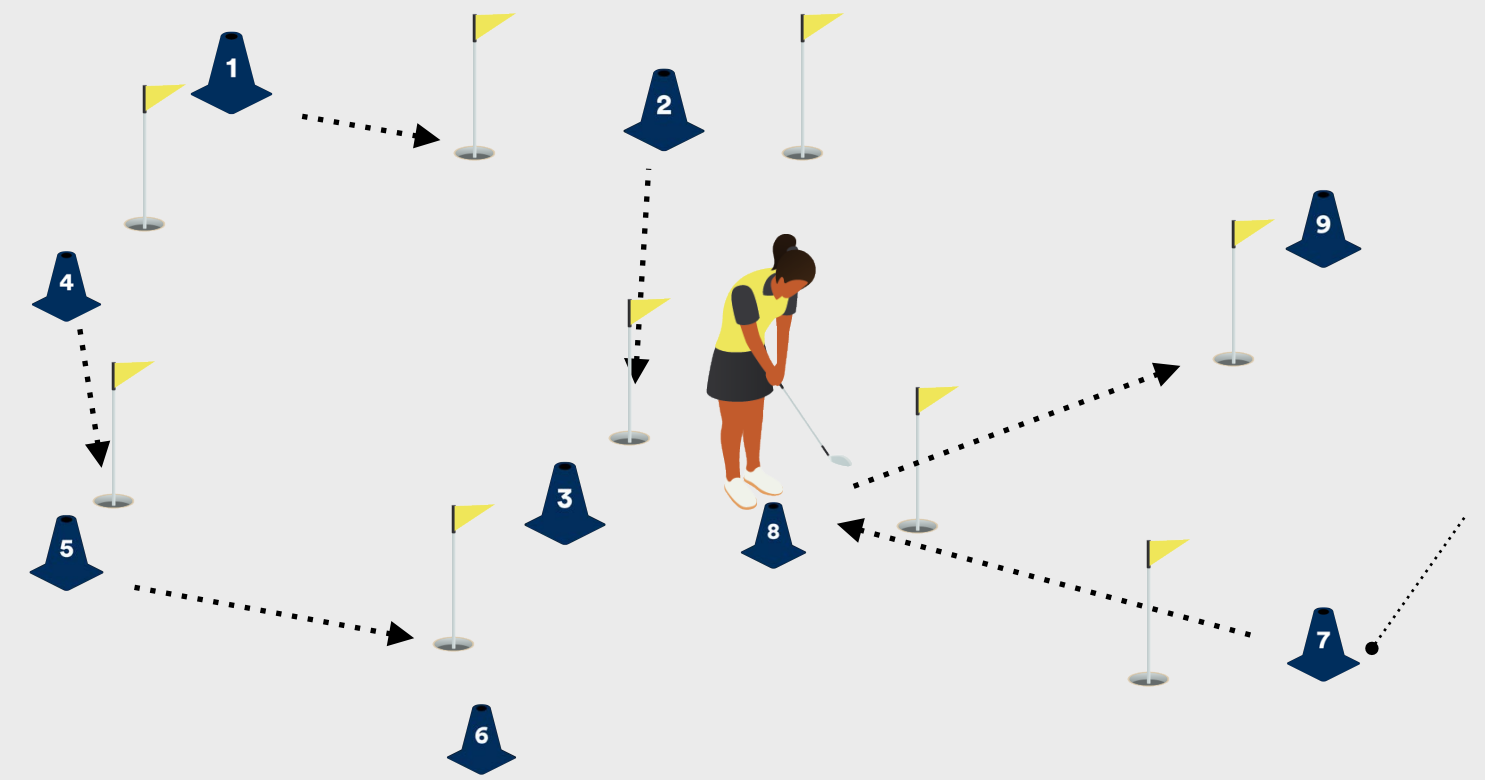

Practice Stations and Game Cards



Themed Class Plans

Control Distance

© 2021 Powered by Orbis Golf

About
The Practice Station Activity has been built to provide an engaging practice element to your class and provide a focused, themed class focus.

Equipment Needed

- 12 cones
- Golf balls

How to Practice

- Set this activity up in 3 different sized boxes (10, 20, and 30 yards) from the learner.
- The learner should practice chipping the ball at different distances using the same club, by varying the speed of the swing.
- Encourage them to start by controlling the length of the stroke, similarly to how they learnt to control the ball further, and then gradually increase the length of the stroke and speed of the stroke to ball further.
- This practice is learnt using the same club as a lower lofted club, e.g. a 7 iron would be best to

Technical Learning Objectives

- This activity will help the learner to understand the distance of a shot based on the speed of the stroke.
- This activity will help the learner to gain consistency in chipping around the green by becoming confident in using one particular type of club.

GAMEON
GOLF DEVELOPMENT

Understanding Slopes

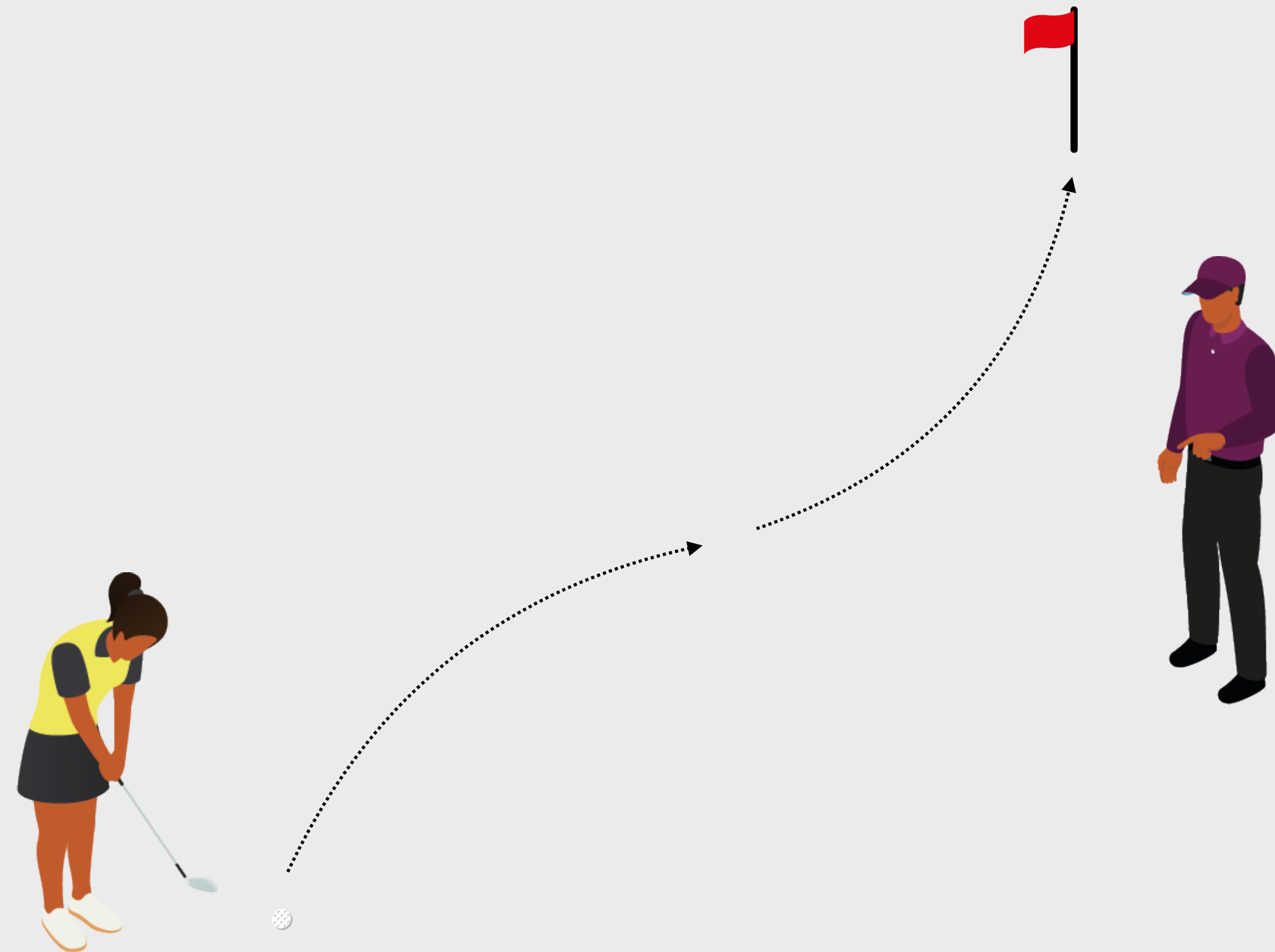

Equipment Needed

- Putter
- Golf Ball

How to Practice

- Help learners to choose a putt with multiple break
- Before taking their putt they should split the putt into sections and be able to tell you or their partner the break of each section of the putt
- The learner should be able to more easily determine the starting line of the putt once they have worked out the different slopes that are having an impact on the line of the putt
- Encourage working in pairs so that learners can openly discuss and help each other learn how to accurately read the slope on the green

Technical Link

- This activity will help the learner to understand how to read a green that has multiple break

Pick a Point

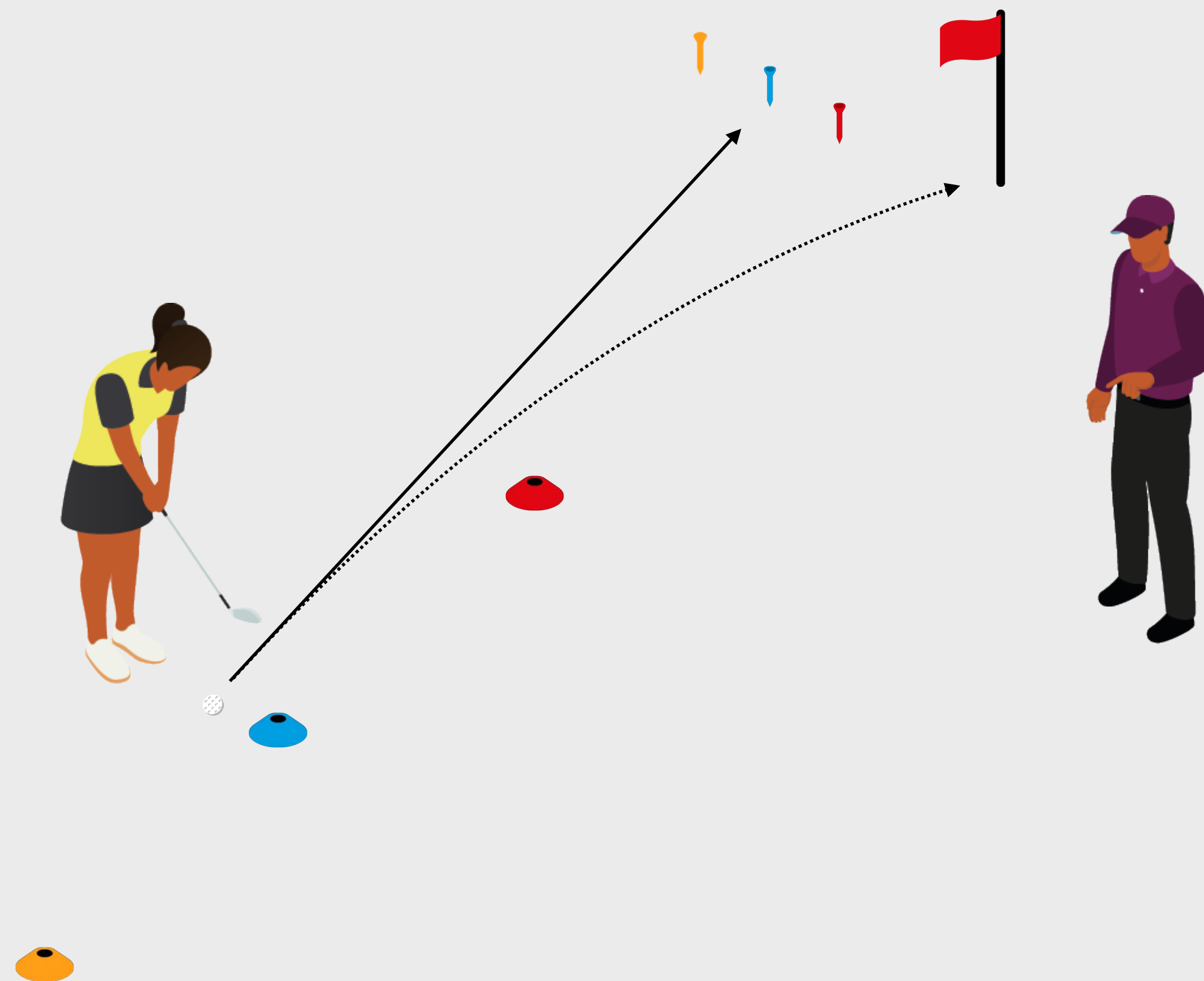

Equipment Needed

- 3 Tee Pegs
- 3 Cones
- Putter
- Golf Ball

How to Practice

- Set this activity up on a sloped surface with 3 cones placed at 10, 20 and 30 feet from the hole
- Get the learner to place the corresponding tees level with the hole, and explain how even though the putt is the same direction there are differing amounts of break due to the length of the putt
- The learner should attempt the putts and based on the feedback of whether the ball missed high or low they should adjust their aim (and the tee position) accordingly
- Be sure to help the learner understand that speed of putt will have an effect on how soon the putt breaks, and therefore this should be taken into account when choosing where to aim
- Encourage the learners to work in pairs here to ensure correct aim at the start and to notice if a putt was just misaligned or mis-hit

Technical Link

- This activity will help the learner to understand how to aim effectively on a sloped surface, especially with respect to longer putts

Gate Challenge

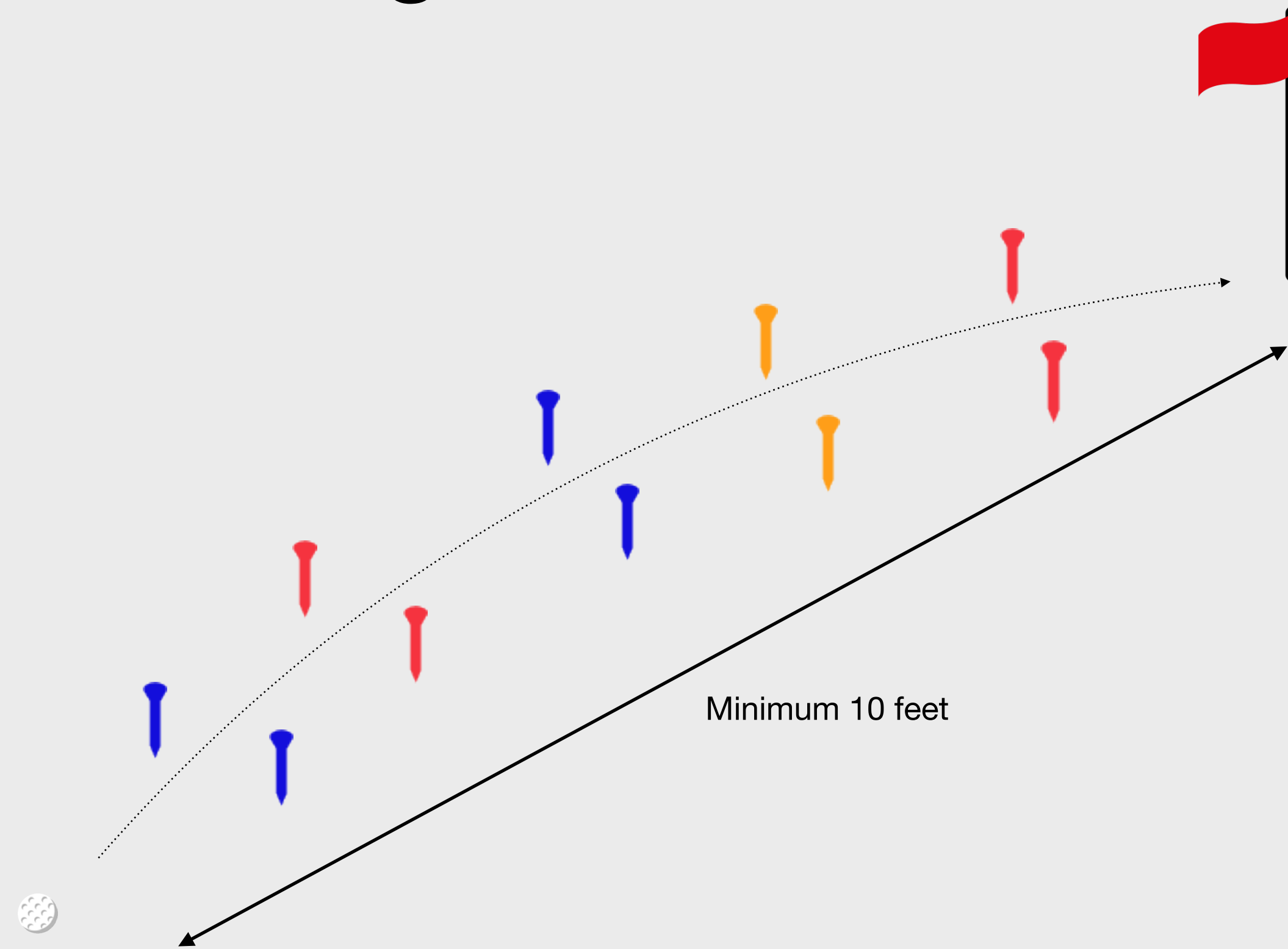

Equipment Needed

- 10 Tee Pegs
- Putter
- Golf Ball

How to Practice

- Set up the tee pegs on a slope as gates for the learners to try and hit the putt through at the appropriate pace for the ball to miss the tees
- As the learner improves, narrow the size of the gates, or increase the number of gates/distance of the putt

Technical Link

- This activity will help the learner to understand the break of a putt over the length of the putt as a whole
- It will help them to understand how length of putt affects the break and how to aim appropriately

Guess the Break

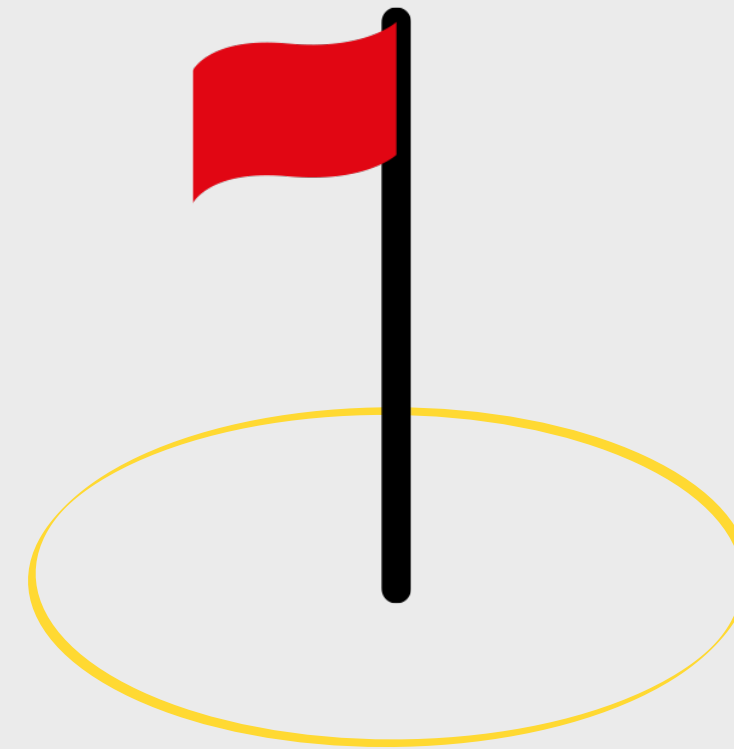
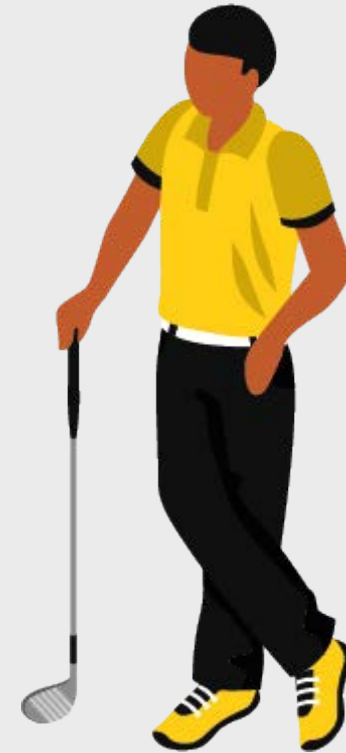
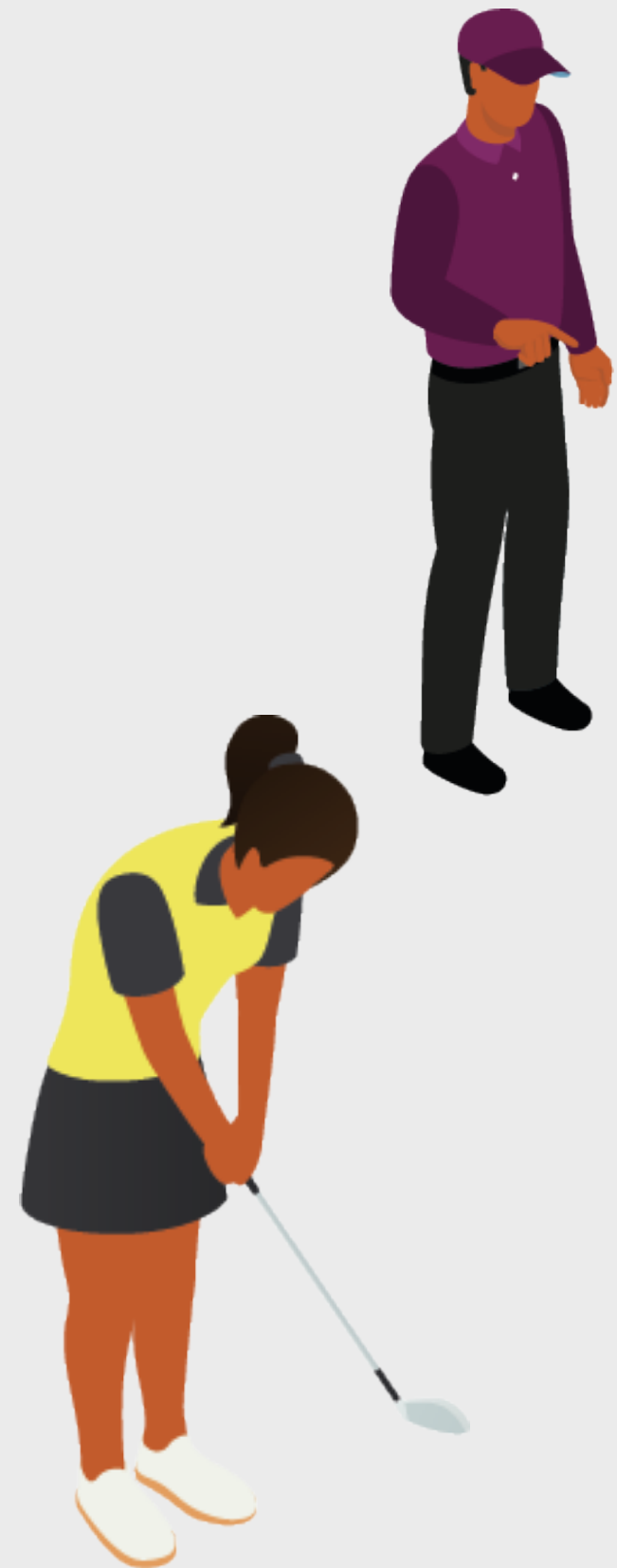

Equipment Needed

- A coin or ball marker

How to Play

- A learner predicts the half-way point of the putt
- The purpose is to note how the slope changes around the hole and therefore the learner needs to adapt where they are aiming
- We suggest framing this as an opportunity to learn the slope on a green, although it can be played competitively, seeing how many putts each learner can hole
- This game can be played individually, in pairs or small groups

Progression Ideas

- Play on a more severely sloped surface
- Introduce a competitive element
- Increase or decrease the length of the putts

Secondary Skill

To allow for variety of practice during the session, and to enable those that may have missed a class to catch up on practicing some of the other skills we recommend having one of the stations set up as a secondary skill.

This week's secondary skill is **pitching**, providing learners an opportunity to practice what was learnt in the around the green class.

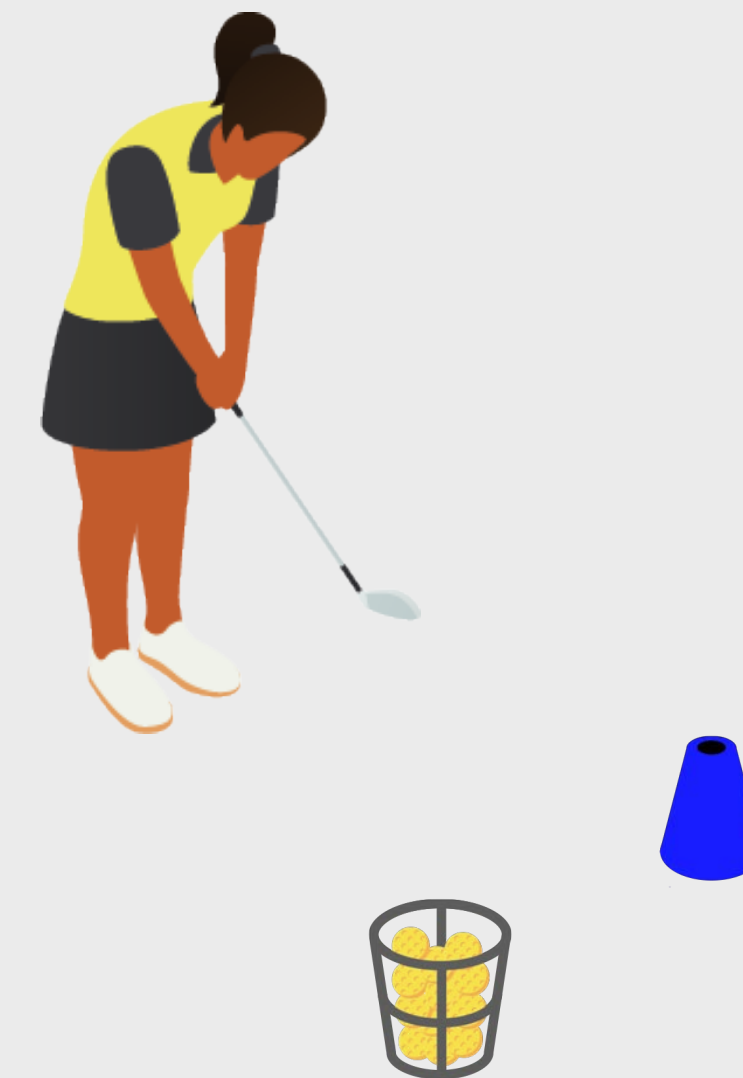
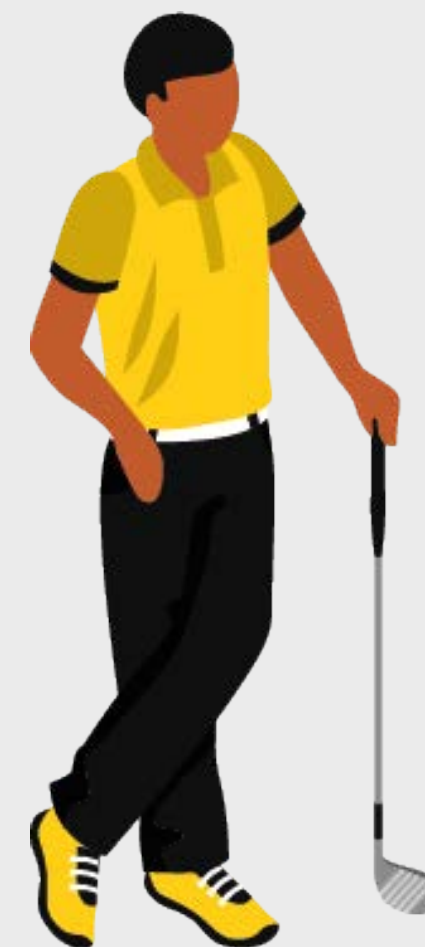

Scoring Challenge

Option 1:

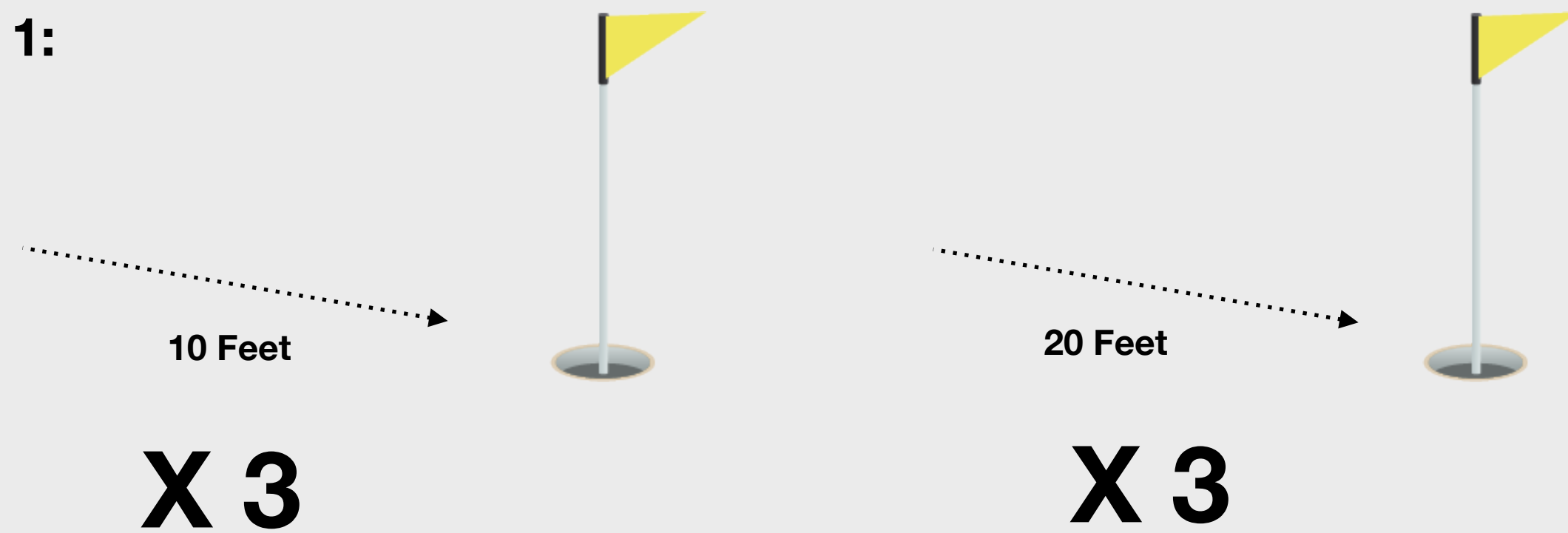

24 putts
or fewer

Option 2:

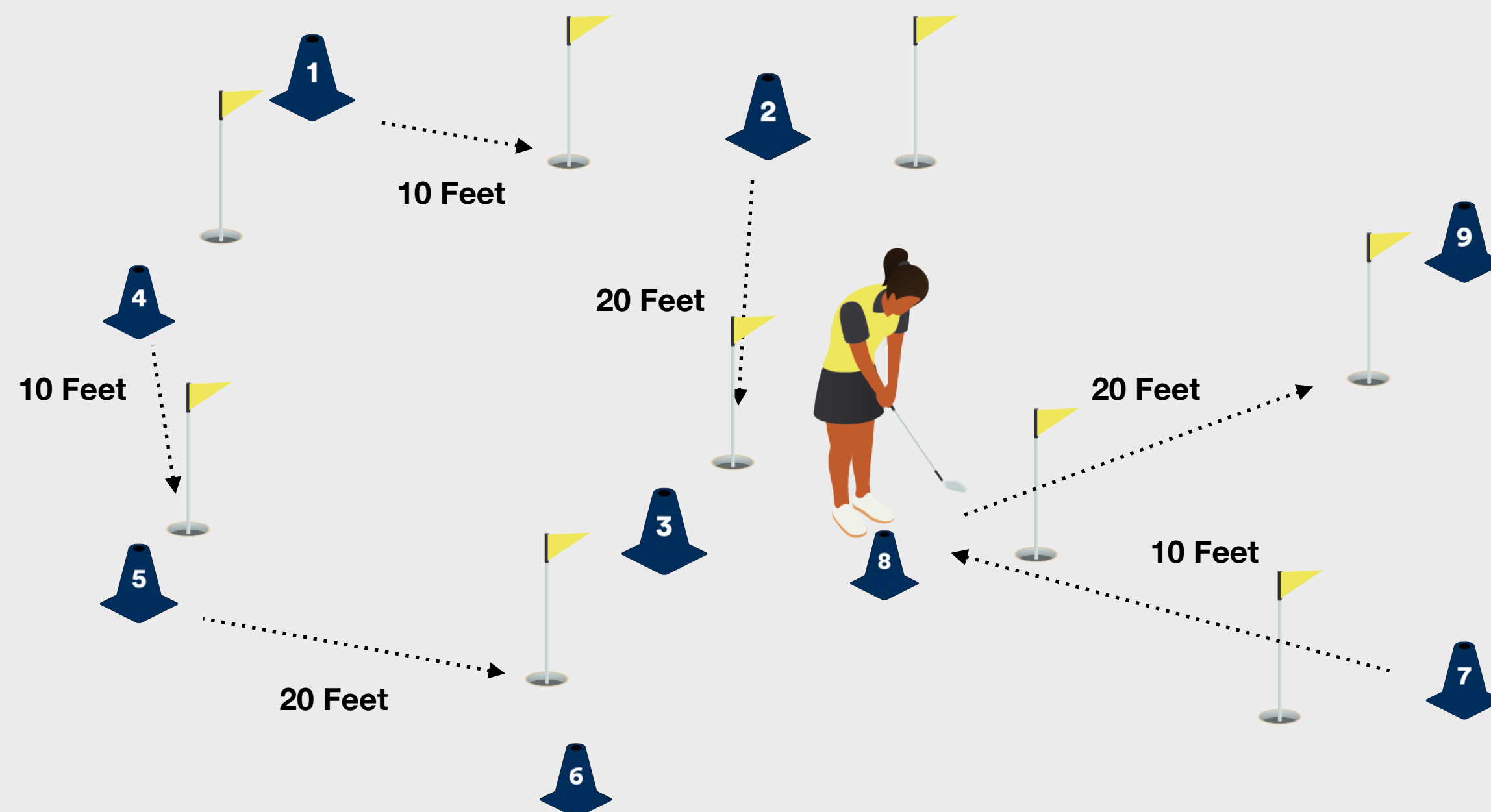

The Challenge

To complete the Level 1 Challenge the learner needs score 24 putts or less over 6 holes. 3 putts should be attempted starting from 10 feet and 3 putts from 20 feet from the hole.

Equipment you Need

The equipment you will need for this challenge:

- Numbered cones from your equipment bag to mark the starting positions.
- Golf Balls
- Scorecard and pencil

What should the Learner do next?

After attempting the challenge, the learner should:

- Log in to the GLF.Locker App
- If they complete the challenge, mark it as complete in the Challenge Section

Scoring



Scoring Challenge

Option 1:

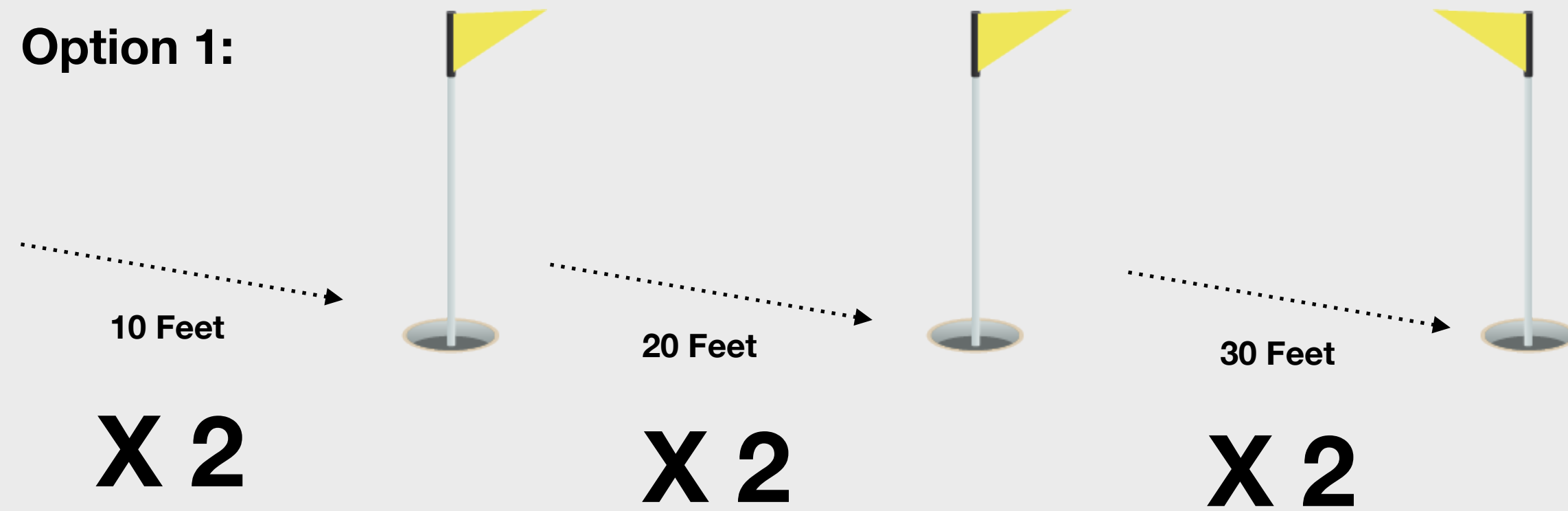

21 putts or fewer

Option 2

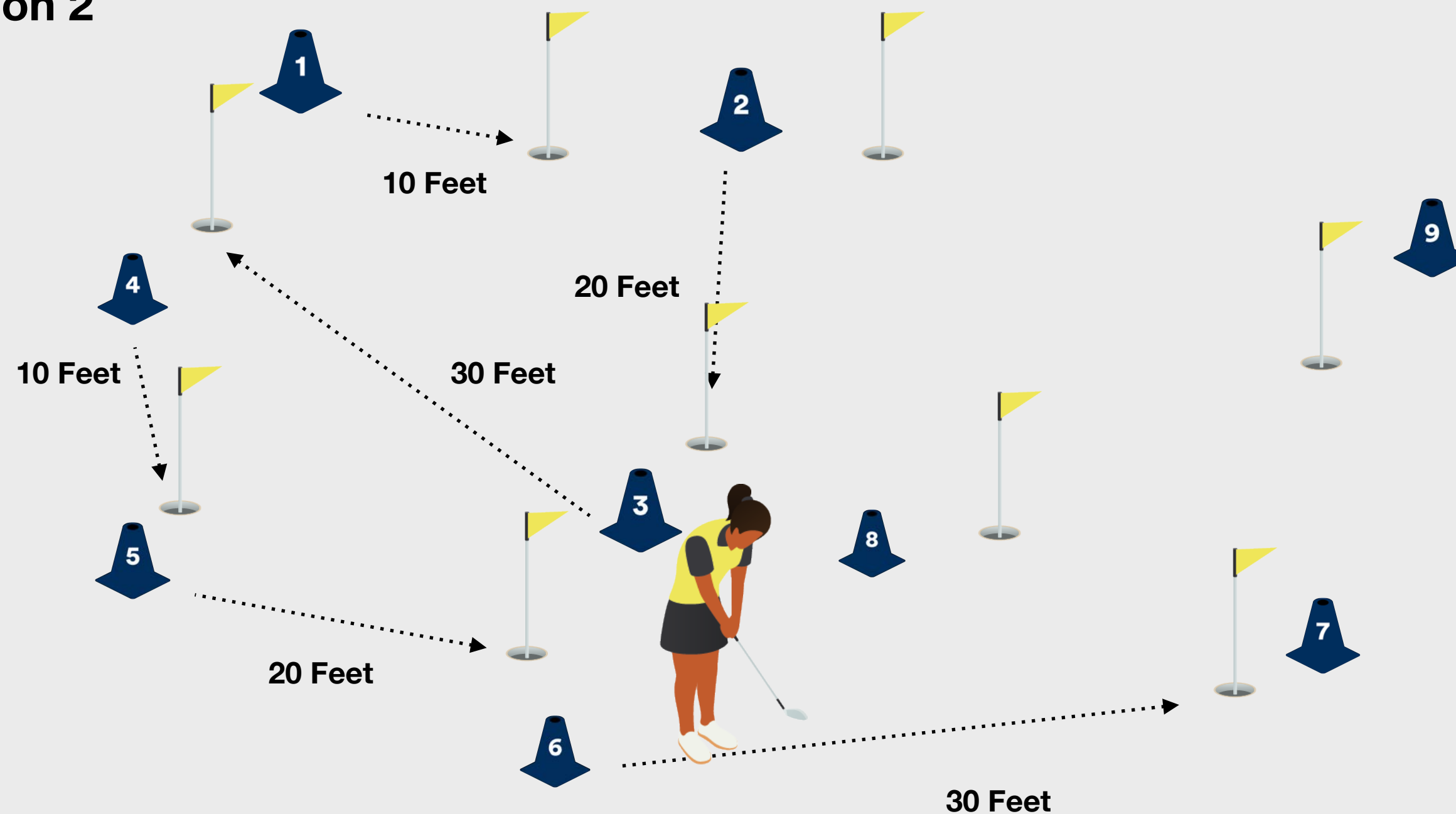

The Challenge

To complete the Level 2 Challenge the learner needs score 21 putts or less over 6 holes. 2 putts should be attempted from a starting position 10 feet, 2 putts from 20 feet and 2 putts from 30 feet from the hole.

Equipment you Need

- The equipment you will need for this challenge:
- Numbered cones from your equipment bag to mark the starting positions.
 - Golf Balls
 - Scorecard and pencil

What should the Learner do next?

- After attempting the challenge, the learner should:
- Log in to the GLF.Locker App
 - If they complete the challenge, mark it as complete in the Challenge Section

Scoring



Scoring Challenge

Option 1:

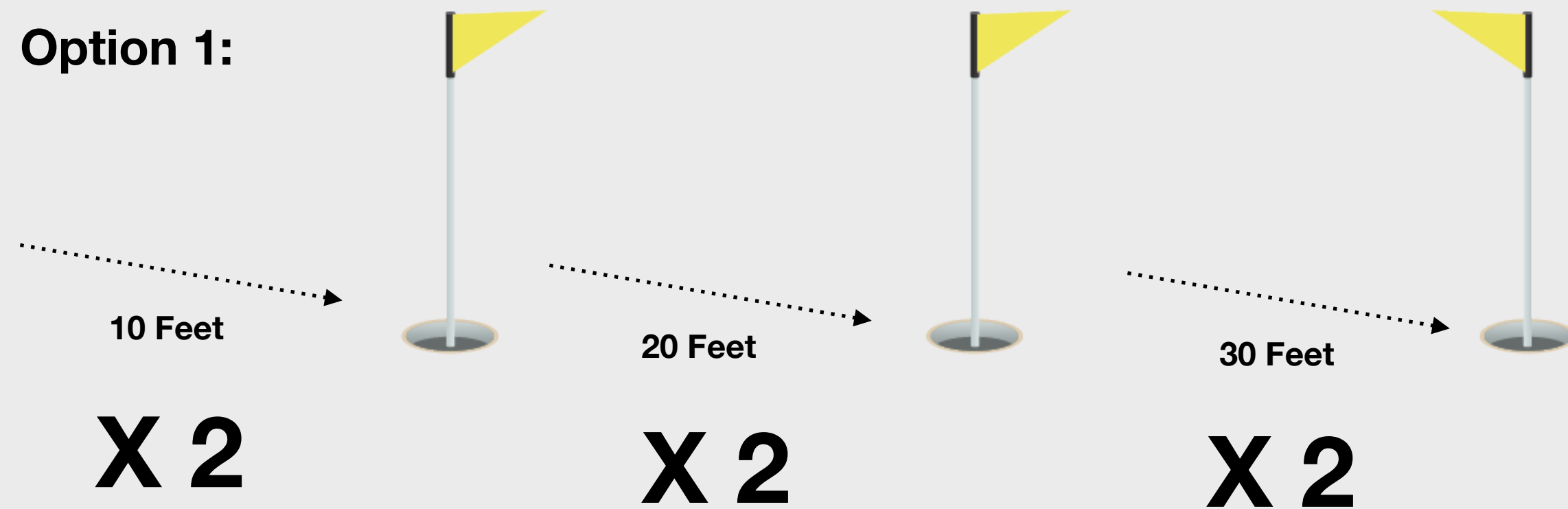

21 putts or fewer

Option 2

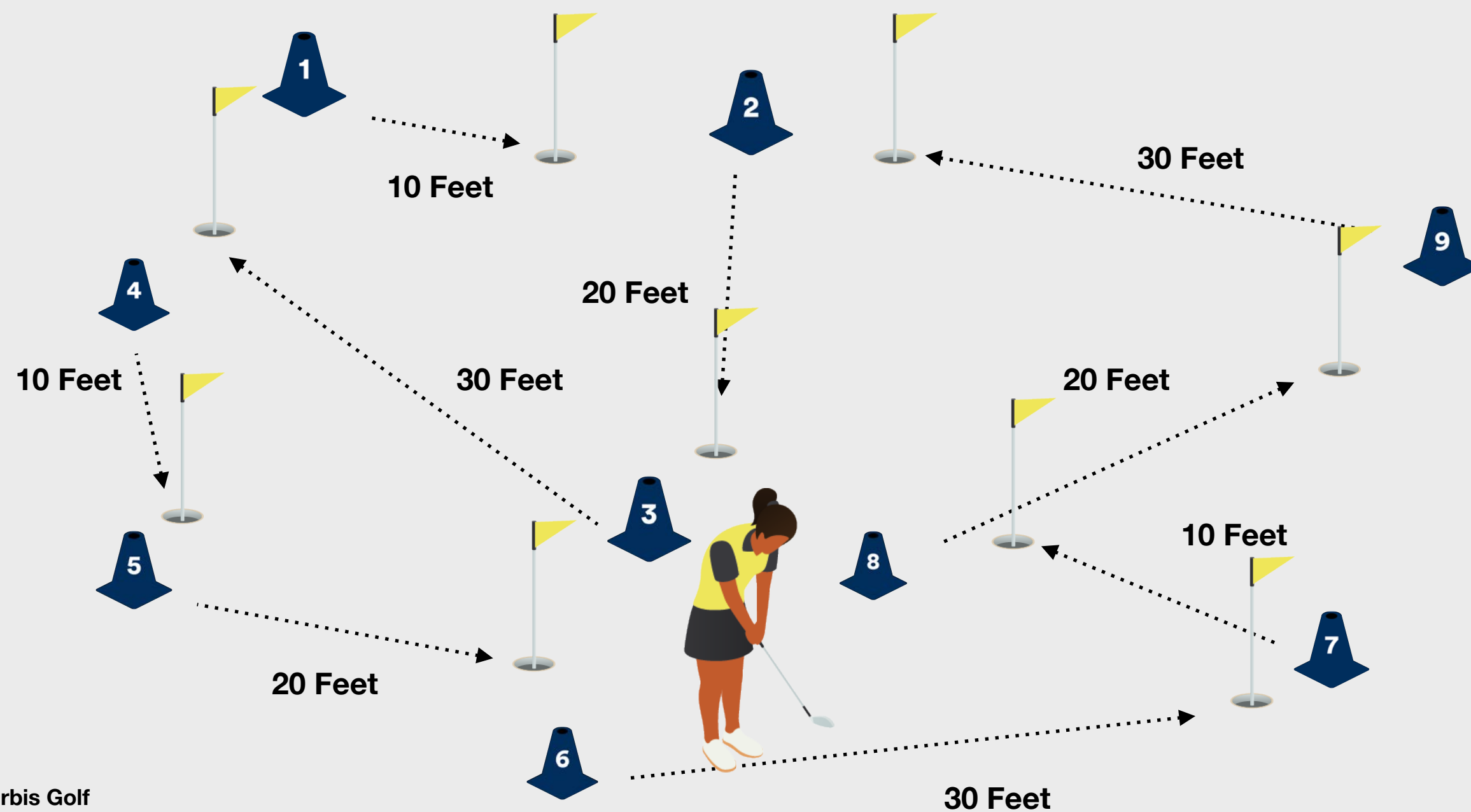

The Challenge

To complete the Level 3 Challenge the learner needs score 21 putts or less over 9 holes. 3 putts should be attempted from a starting position 10 feet, 3 putts from 20 feet and 3 putts from 30 feet from the hole.

Equipment you Need

The equipment you will need for this challenge:

- Numbered cones from your equipment bag to mark the starting positions.
- Golf Balls
- Scorecard and pencil

What should the Learner do next?

After attempting the challenge, the learner should:

- Log in to the GLF.Locker App
- If they complete the challenge, mark it as complete in the Challenge Section

Scoring

